

## **Predictive mycology: some definitions**

*P. DANTIGNY\**, *A. GUILMART* & *M. BENSOUSSAN*

*Université de Bourgogne. Laboratoire de Microbiologie,  
UMR INRA 1232, ENS.BANA,  
1, Esplanade Erasme, 21000 Dijon, France*

**Abstract** – Predictive mycology aims at predicting fungal development in foods and raw products. For 25 years, most of the studies concerned food pathogenic bacteria. Recently, there is a growing concern about food contamination by moulds, especially strains responsible for mycotoxins production. This paper advocates the use of specific models for describing germination and growth of fungi.

*Mucor racemosus* / *Penicillium chrysogenum* / germination and growth modelling

### **INTRODUCTION**

Under favourable environmental conditions, moulds can grow on a wide variety of substrates. Losses due to mould spoilage vary between 1% and 5% of products depending on season, type of product and method of processing (Malkki & Rauha, 1978). In addition to the economic losses, a further concern is the possibility that mycotoxins produced by moulds may cause public health problems. Therefore there is a need for developing tools for predicting and controlling fungal development. Such tools have been developed for 25 years for predicting the growth of pathogenic food-borne bacteria.

Due to difficulties in acquiring sufficient, reproducible data, there is a shortage of models dedicated to describe fungal growth. Therefore there is a tendency of using existing models that were developed for bacteria. Mycologists are more often unable to choose between the different proposed models. Furthermore, these models may not take into account the moulds specificities. After a brief review of the basis of predictive microbiology, the main differences between bacterial and fungal development will be described. Thereafter, the reader will be provided with some examples of models which have been developed specifically for moulds.

### **PREDICTIVE MICROBIOLOGY**

Microbial responses are measured under defined and controlled conditions and the results are summarised in the form of mathematical equations which, by interpolation and sometimes extrapolation, can predict responses to novel sets

---

\* Correspondence and reprints: [phdant@u-bourgogne.fr](mailto:phdant@u-bourgogne.fr)

This paper was presented at Journées du Réseau Mycologie de Nancy 15-17 january 2002

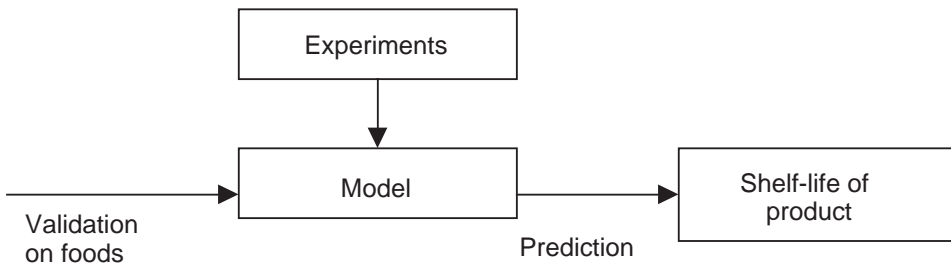

Fig. 1. Protocol for designing a predictive model.

of conditions, (i.e., those which are not actually tested). Proponents claim that such an approach will enable (Ross & McMeekin, 1994):

(1) prediction of the consequences, for product shelf-life and safety, of changes to product formulation, and enable the rational design of new processes and products to meet required levels of safety and shelf-life;

(2) objective evaluation of processing operations and, from this, an empowering of the HACCP approach;

(3) objective evaluation of the consequences of lapses in process and storage control.

First, the organisms that are responsible for food contamination and spoilage should be identified. Thereafter each organism is studied independently from the others according to the approach schematised in Fig. 1. Within an experimental domain, experiments are carried out, thus leading to mathematical models. The response is usually the number of organisms ( $N$ ) per unit of volume or weight. These models are articulated into two distinct classes: primary models (either kinetic  $N=f(t)$ , or probabilistic  $p(N>N_a)$  at  $t=t_a$ ) and secondary models which describe the influence of environmental factors on parameters of the primary model. Once these models are designed, the key step of the approach is the validation of the model on food. This step, which should not be mistaken with data fit, consists in comparing the experimental results found in food with the model predictions. Once this step is successful, the model predictions can be utilised thus avoiding the use of time costing experiments.

## MOULD SPECIFICITIES

Due to their ability of dividing, bacteria form single cells and they can be easily enumerated especially in liquid broth. In such a case, and at high cellular densities, bacterial growth can be estimated automatically for example by using bioScreen<sup>®</sup> device based on turbidity measurements. At lower cellular densities and in solid media, CFU/g or CFU/ml can be determined.

In contrast, moulds are forming mycelium whose weight, except at the early stage of growth, does not increase exponentially (Koch, 1975). It is therefore useless to determine the weight of the mycelium for estimating a growth rate parameter. In addition, it is impossible to split the mycelium into individual cells.

Table 1. Mould specificities which should be taken into account for modelling fungal development.

<i>Organism</i>	<i>Mould</i>	<i>Bacteria</i>
Medium for modelling	Solid	Broth
Cells	Mycelium	Individual
Key factors	Water activity, Oxygen	Temperature
Development	Germination and growth	Growth

Therefore, the CFU method can be applied to the enumeration of spores only, (Vindeløv & Arneborg, 2002).

Temperature (T) is the main factor for controlling bacterial growth, but the effect of water activity ( $a_w$ ) on mould growth is more important than T (Holmquist *et al.*, 1983). Oxygen is necessary for the growth of food spoilage fungi. Therefore, the use of modified atmospheres to prevent fungal growth and mycotoxin production was evaluated to extend the shelf-life of some kinds of food (El Halouat & Debevere, 1997; Taniwaki *et al.*, 2001).

Fungal growth involves germination and hyphal extension. Germination can be considered as the main step to be focused on, because a product is spoiled as soon as visible hyphae can be observed. However, few studies have concerned germination kinetics. This shortage can be explained by the difficulties of acquiring sufficient, reproducible data. In fact, this kind of study requires microscopic observation for evaluating the length of the germ tube. Moreover, observations and measurements should be carried out without opening the dishes (Magan & Lacey, 1984) and experimental devices should be developed for this purpose (Sautour *et al.*, 2001a, 2001b). In contrast, more work was dedicated to the measurement of hyphal extension rate, which is usually reported as radial growth rate ( $\text{mm d}^{-1}$ ).

## PRIMARY MODELS

**1. Germination** is a process that breaks dormancy. This process is characterized by three steps (i.e., activation, swelling and emergence of germ tube). Spores are not forming germ tubes at the same time, therefore the definition of the germination time depends on i/ when is a spore considered to have germinated ii/ which percentage of germinated spores should be chosen for claiming germination. Usually spores are considered germinated when they have produced a germ tube of length equal to or greater than half, the spore diameter or twice the spore diameter. It is shown in Figure 2, that germination kinetics of *Mucor racemosus* sporangiospores depend on this definition. From these curves, two parameters can be defined (i.e., the lag time for germination or latent period, and the germination time). Although no accepted definition for these parameters exists, the lag is less than equal than the germination time. The lag can be considered as the time at which germination starts (e.g., last time for  $P = 0\%$ ). However, this definition is not precise enough. If the model fit at  $15^\circ\text{C}$  (plain symbols) is considered, the lag time for germination is 10h. But if the experimental data are consi-

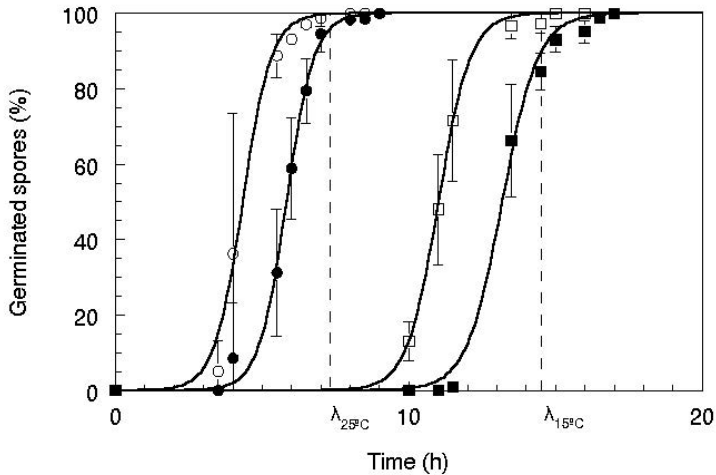

Fig. 2. Germination of *Mucor racemosus* on PDA at 25°C (●, ○) and 15°C (■, □). Spores are considered germinated when the length of the germ tube was equal to one half (open symbols) or twice (plain symbols) the spore diameter. Error bars are standard deviations.

dered, this time is 11h. Similarly, if the germination time is defined as the time for obtaining 10, 20 or 50% of germinated spores, it is very unlikely that this time coincided with a sampling time. Therefore, it is proposed that a germination curve is drawn from the experimental data, and fit with the help of a primary model for germination. Thereafter, definitions for the lag time and the germination time could be given, and these parameters estimated by the model. Two models for fitting the germination data can be used:

$$\text{the Gompertz equation } P = A \exp(-\exp[\mu_m e/A(\lambda - t) + 1]) \quad (1)$$

$$\text{the logistic function } P = P_{\max} / (1 + \exp(k(\tau - t))) \quad (2)$$

By using any of these equations, it is possible to estimate accurately the time necessary to reach a certain percentage of germination. For example, the time at which 50% of the maximum percentage of germination is defined as:

$$t_i = \lambda + A/(\mu_m e(1)) \text{ and } t_i = \tau \text{ for equations (1) and (2) respectively.}$$

Germination time is an early criterion for determining the shelf-life of a product because visible hyphae appears shortly after germination (Dantigny *et al.* 2002). But spore germination requires microscopic observation. Therefore, it would be advantageous to substitute a macroscopic examination for a macroscopic one.

**2. Growth** is usually reported as the radial extension rate ( $\text{mm.d}^{-1}$ ) of a colony grown on plate agar medium. This method, as shown on Figure 3 usually exhibits regression coefficients close to 1. This technique also provides a lag time for growth. Under carefully controlled inoculum, it was shown that the lag time for *Mucor racemosus* growth coincided with the completion of the germination. At present this promising approach cannot be used because the lag time for growth is greatly dependent upon the size of inoculum, (i.e., the number of spores which were inoculated).

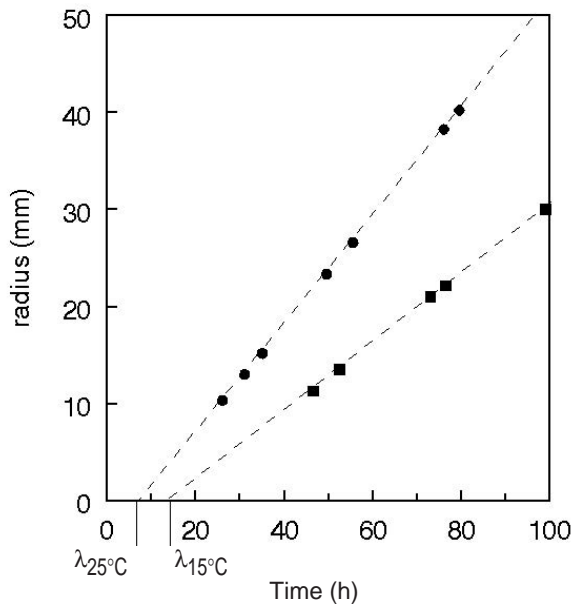

Fig. 3. Radial growth rate and lag time of *Mucor racemosus* grown on PDA at 25°C (●) and 15°C (■). Error bars are too small to be visible. From Dantigny et al., 2002.

## SECONDARY MODELS

Secondary models describe the influence of environmental factors on key parameters of the primary models. Two approaches can be identified, i/ the factors are studied independently (e.g., progressive approach), ii/ several factors are studied according to experimental matrixes (e.g., polynomial approach). The latter one is interesting since the number of experiments is very low as compared to the information which is provided. In the following example, the influence of environmental factors (i.e., water activity, temperature and pH) on the time to obtain 90% of *Penicillium chrysogenum* conidiospores germinated was assessed by means of a Doehlert design (13 experiments only were needed to identify the parameters of the model (Sautour *et al.* 2001b). A response surface methodology illustrates on Figure 4 how the germination time can be predicted.

pH which is usually associated to other environmental factors to prevent bacterial growth has no marked influence on mould growth in the experimental domain 3.5-6.5. In this domain, results shown that  $a_w$  had a greater effect on germination than temperature. In addition, there is a significant interaction effect between these variables. However, any extrapolation outside the domain, or to other moulds would be hazardous. Therefore the progressive approach, which is based on parameters with biological significance (e.g., the cardinal values) has a more generalised application, but it takes longer time to design this kind of models.

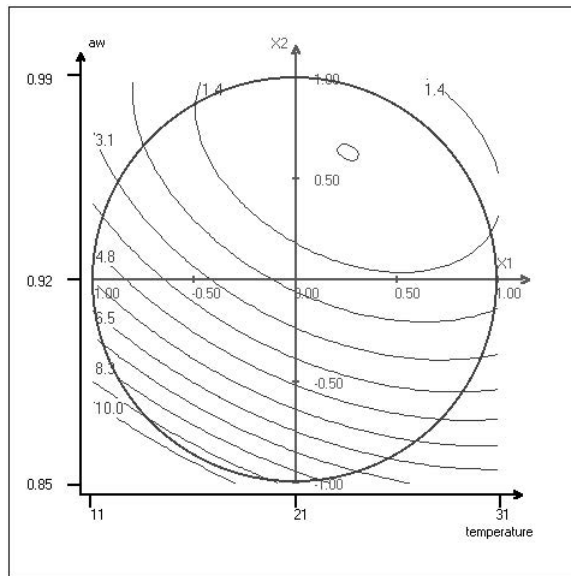

Fig. 4. Contour plot of the influence of water activity and temperature at pH 5 on time  $T_{90}$  to obtain 90% of the conidia of *P. chrysogenum* germinated on YNB-Glucose Agar medium for glycerol as humectant.

## CONCLUSION

Mould contamination of food and raw materials causes economic losses but also constitutes a risk for human health. Mycotoxin ingestion by humans, which occurs mainly through plant-based foods and the residues and metabolites present in animal-derived foods; can lead to deterioration of liver or kidney function (Sweeney & Dobson, 1998). Other mycotoxins are neurotoxins. Therefore, predictive microbiology whose concern for more than 20 years was mainly food pathogenic bacteria should extend its domain of study to moulds. The objectives and the methods developed throughout in predictive microbiology can be applied for this purpose, but mould specificities should be taken into account.

**Acknowledgements.** This research was partially supported by ACTIA, contract 00.06.

## REFERENCES

- DANTIGNY P., SOARES MANSUR C., SAUTOUR M., TCHOBANOV I. & BENSOUSSAN M., 2002 — Relationship between spore germination kinetics and lag time during growth of *Mucor racemosus*. *Letters in Applied Microbiology* 35: 395-398.

- EL HALOUAT A. & DEBEVERE J.M., 1997 — Effect of water activity, modified atmosphere packaging and storage temperature on spore germination of moulds isolated from prunes. *International Journal of Food Microbiology* 35: 41-48.
- HOLMQUIST G.U., WALKER H.W. & STAHR H.M., 1983 — Influence of temperature, pH, water activity and antifungal agents on growth of *Aspergillus flavus* and *A. parasiticus*. *Journal of Food Science* 48: 778-782.
- KOCH A.L., 1975 — The kinetics of mycelial growth. *Journal of General Microbiology* 89: 209-216.
- MAGAN N. & LACEY J., 1984 — Effect of temperature and pH on water relations of field and storage fungi. *Transactions of the British Mycological Society* 82: 71-81.
- MALKKI Y. & RAUHA O., 1978 - Mould inhibition by aerosol. *Baker's Digest* 52: 47.
- ROSS T., & MCMEEKIN T.A., 1994 — Predictive microbiology. *International Journal of Food Microbiology* 23: 241-264.
- SAUTOUR M., ROUGET A., DANTIGNY P., DIVIES C. & BENSOUSSAN M., 2001a — Prediction of conidial germination of *Penicillium chrysogenum* as influenced by temperature, water activity and pH *Letters in Applied Microbiology* 32: 131-134
- SAUTOUR M., DANTIGNY P., DIVIES C. & BENSOUSSAN M., 2001b — Application of Doehlert design to determine the combined effects of temperature, water activity and pH on conidial germination of *Penicillium chrysogenum*. *Journal of Applied Microbiology* 91: 900-906
- SWEENEY M.J. & DOBSON A.D.W., 1998 — Mycotoxin production by *Aspergillus*, *Fusarium* and *Penicillium* species. *International Journal of Food Microbiology* 43: 141-158.
- TANIWAKI M.H., HOCKING A.D., PITT J.I. & FLEET G.H., 2001 — Growth of fungi and mycotoxin production on cheese under modified atmospheres. *International Journal of Food Microbiology* 68: 125-133.
- VINDELØV J. & ARNEBORG N., 2002 — Effects of temperature, water activity, and syrup film composition on the growth of *Wallemia sebi*: development and assessment of model predicting growth lags in syrup agar and crystalline sugar. *Applied and Environmental Microbiology* 68: 1652-1657.